

ingenico

AXIUM EX-MBASE-W1

User Guide

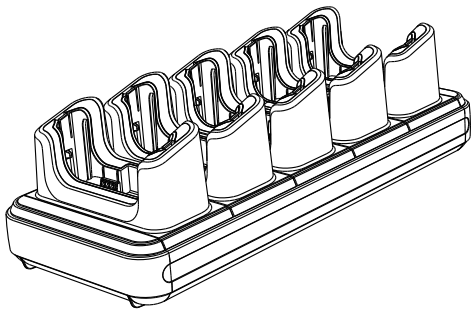

www.ingenico.com

13-17 rue Pagès, 92150 Suresnes – France

Banks and Acquirers International Holding, SAS / 814 767 216 RCS Nanterre



UYS01000575



Contents

Table of Contents	2
1. Product Introduction	3
1.1 What's in the Box – subject to ordered product configuration	3
1.2 Device Layout	3
1.3 Interface definition	3
2. Product Technology Features	4
2.1 Product Technology Specifications	4
2.2 Environmental Conditions	4
2.3 Product Functions	4
2.4 Instructions	5
3. WiFi Connection	6
3.1 Connect EX pos to the base WiFi	6
3.2 Web Setting of base	6
3.3 Restore factory Setting	8
4. BASE Setting From EX pos	9
4.1 Get the Admin permission	9
4.2 Ethernet Parameter Setting	9
4.3 WLAN Parameter Setting	10
4.4 Advanced Setting	10
4.5 Operating Mode	11
4.5.1 Gateway Mode	11
4.5.2 Bridge Mode	11
4.5.3 WiFi Repeater Mode	12
4.6 Management Setting	13
4.6.1 Upgrade the firmware of base	13
4.6.2 Save the setting of base	14
4.6.3 Load the setting of base	14
5. FAQs	15
6. Notes	15
7. Delivery and Storage	15
8. Power Adapter	16
9. Standard	16

1. Product Introduction

1.1 What's in the Box – subject to ordered product configuration

- Base host
- User Guide
- 12V/3.33 A power adapter
- AC power cable
- USB type-B cable
- 5 AXIUM EX8000 Bushings
- 5 AXIUM EX6000 Bushings

1.2 Device Layout

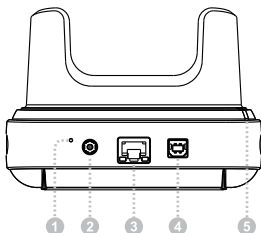

1) Reset Button	2) DC JACK Power Interface	3) RJ45 Network Interface
4) USB – Type B	5) Power LED	

1.3 Interface definition

1) RJ45 interface

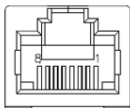

Sequence	RJ45 Signal
1	ETH_TX+
2	ETH_TX-
3	ETH_RX+
4	NC
5	NC
6	ETH_RX-
7	NC
8	NC

2) USB-TYPE B interface

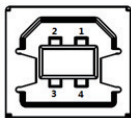

Sequence	USB-TYPE B Signal
1	Not connect
2	D-
3	D+
4	GND

2. Product Technology Features

2.1 Product Technology Specifications

Port	a DC JACK power port a RJ45 network port a USB B DEVICE port supporting USB2.0
Power	Every Charge output: 5.0VDC 1.0A Power adapter: input 100-240V AC, 50/60Hz; output 12.0V DC 3.33A
Size and Weight	Size: 311mmx127.8mmx91mm Net Weight : 0.76kg Gross Weight: 1.50kg

2.2 Environmental Conditions

Environmental conditions for transportation, storage and operation

Temperature	Operating	0°C ~ 40°C / 32°F ~ 104°F
	Storage and Delivery	-20°C ~ 70°C / -4°F ~ 158°F
Relative Humidity	Operating	10% ~ 90%
	Storage and Delivery	5% ~ 90% (at 40°C) / (104°F)
Atmospheric pressure		86kPa ~ 106 kPa; 2000 meters above sea level

2.3 Product Functions

The base has three main functions as below:

- Place EX pos on the base to get charged.
- Place EX pos on the base. Connect the USB type-B to computer to extend the USB port.
- Serves as a router. EX pos can connect to the base via WiFi to extend the network.

2.4 Instructions

The base supports three types of terminal configurations:

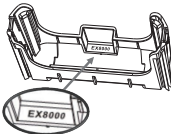
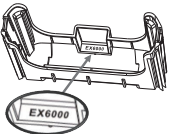
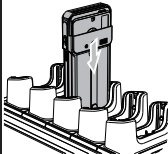
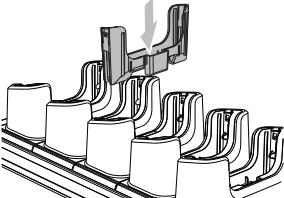
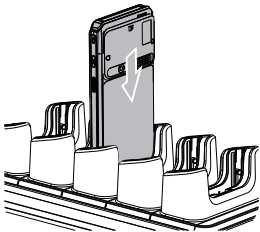
AXIUM EX8000 with shell.	AXIUM EX8000 alone.	AXIUM EX6000 alone.
<p>We can place it on the base directly.</p>	<p>1. Without the shell, we must take the EX8000 black bushing.</p> 	<p>1. We must take the EX6000 grey bushing.</p> 
	<p>2. We must insert the bushing in the base first.</p> 	
<p>Note: the slot base should NOT have any bushing inside.</p>	<p>3. After that we can put EX pos on the base.</p> 	

3. WiFi Connection

3.1 Connect EX pos to the base WiFi

- Power on the base
- Click “Settings” menu on EX pos , and then click “Base” [step 1]
- Click the “scanning box” [step 2], and scan the Data matrix code label on the back of base.
- The EX pos connect to the base successfully.[step 3]
- After that , we can get the “Connected” status.[step 4]

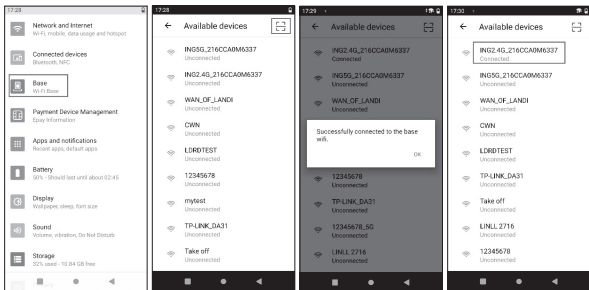

Step1

Step2

Step3

Step4

3.2 Web Setting of base

The base can be set from the web.

- Use a computer to connect the base via WiFi.
- The web setting IP of base is 192.168.47.1. Login name is Admin. Password is the Pairing Password.
(Pairing Password please refer to the rear label for details)
- User can get the status of base on the status page.

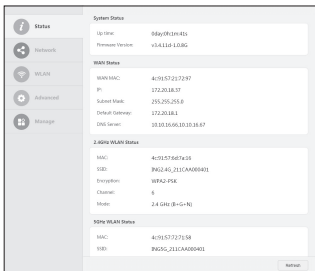

- User can get and change the Ethernet parameter on the Network page.

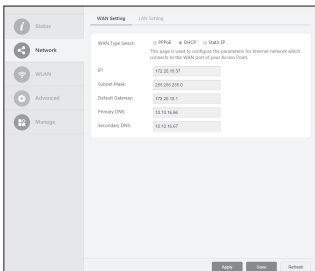

- User can get and change the WLAN parameter on the WLAN page.

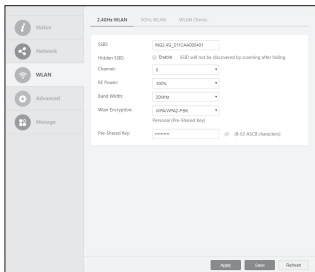

- User can change the operating mode, enable DMZ or set static DHCP on the Advanced page.

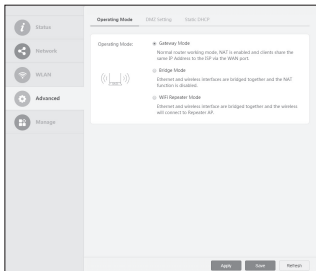

- User can update the firmware of base, save and reload the settings, change the password on the Manage page.

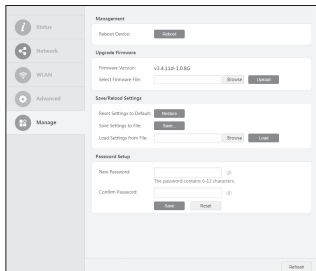

3.3 Restore factory Setting

- Use paperclip to click the RESET button for 3 seconds to restore the factory setting of the base.
- The position of RESET button is in chapter 1.2.

4. BASE Setting From EX pos

4.1 Get the Admin permission

- First, connect EX pos to the base via chapter 3.1.
- Click “SSID” menu on EX pos [step1], and then input the Pairing Password to connect [Step2].
(Pairing Password please refer to the rear label for details)
- After that, we can enter the base menu and get the manager privileges.[Step3].

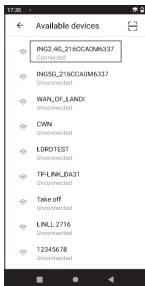

Step1

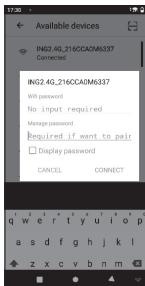

Step2

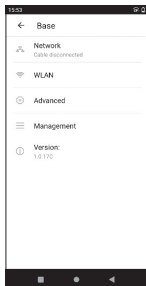

Step3

4.2 Ethernet Parameter Setting

Procedures:

- Tab on “Network” enter WAN Setting or LAN Setting menu.
- Enter WAN Setting to get and set the WAN parameter.
- Enter LAN Setting to get and set the LAN parameter.

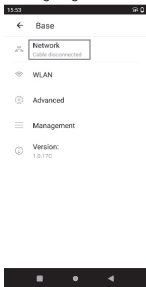

Step1



Step2

4.3 WLAN Parameter Setting

- Enter WLAN menu.[Step1]
- We can click "2.4GHz WLAN" to set 2.4G parameter and click "5GHz WLAN" to set 5GHz WLAN. [Step2]
- We can set channel, RF power, band width and get WLAN MAC on the menu. [Step3,4]

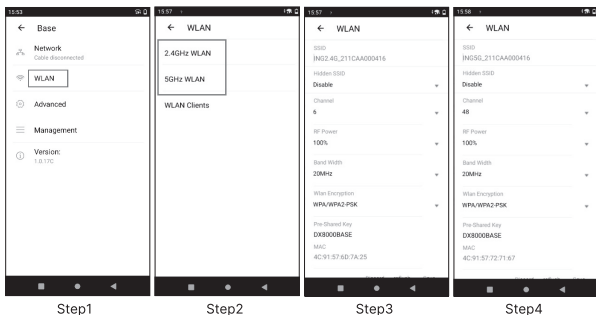

4.4 Advanced Setting

- Enter advanced menu.
- We can set the operating mode,DMZ and static DHCP of the base[Chart 1].
- In operating mode,we can set the base work in different mode [Chart 2].
- We can set DMZ[Chart 3]and add static DHCP[Chart 4].

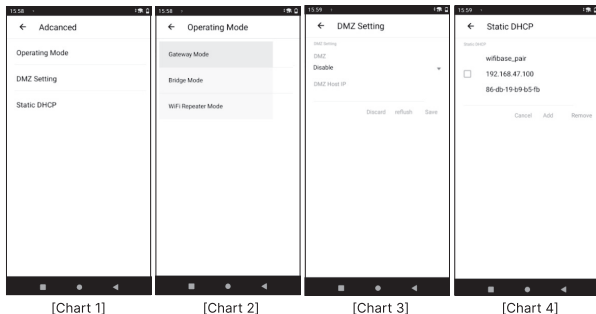

4.5 Operating Mode

4.5.1 Gateway Mode

- Local network/ONU distribute the IP to base ETH port.
- Base distribute the IP to EX pos
- Local network/ONU and EX pos are not in the same network segment .

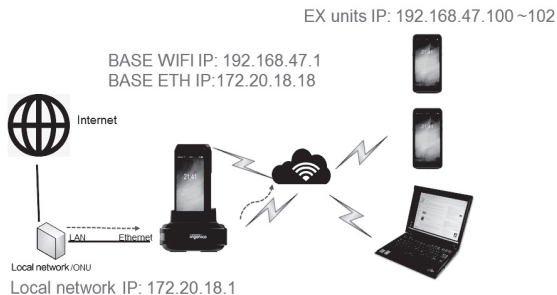

4.5.2 Bridge Mode

- Base distribute the IP to the Local network and EX pos.
- They are in the same network segment .

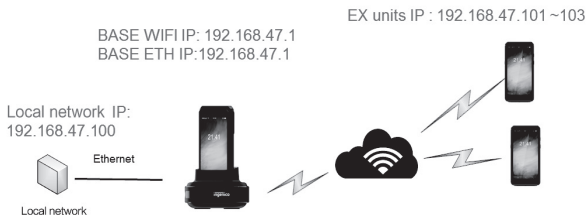

4.5.3 WiFi Repeater Mode

- It is a mode to expand coverage of base.
- For example , Ex pos is too far away to connect Base A. So we can put Base B between Base A and EX pos.
- Set Base B to repeat the Base A. EX pos can connect to internet via Base B.



4.6 Management Setting

4.6.1 Upgrade the firmware of base

- First, we use software manager to install the wifidockfirmware.apk in EX pos, as follow :

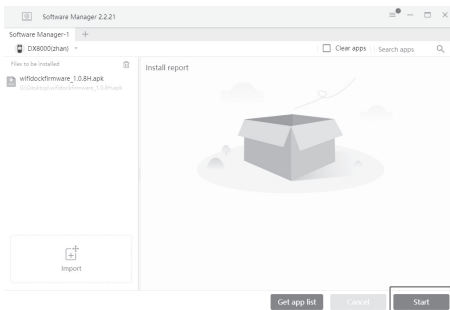

- Second, we get the Admin permission of the base with EX pos via chapter 4.1. Wait for upgrading. [Step1]. And get the successful tips [Step2]. Check the version of the base [Step3].



Step1



Step2

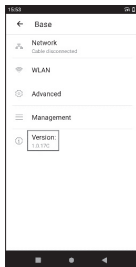

Step3

4.6.2 Save the setting of base

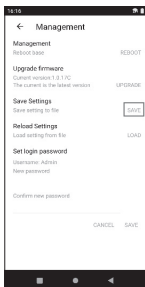

Step1

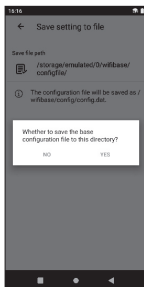

Step2

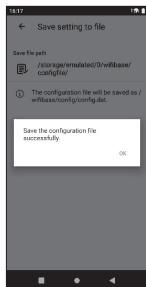

Step3

4.6.3 Load the setting of base

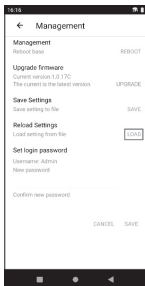

Step1

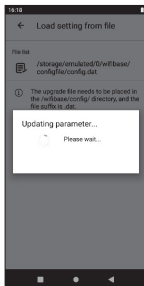

Step2

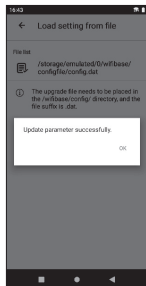

Step3

5. FAQs

Q1: The base fails to connect EX pos.

- Cause1: EX pos WLAN is not yet opened.
- Solution: Open WLAN via the drop-down box of EX pos.
- Cause 2: EX pos is placed too far away from base.
- Solution: Place and connect the devices within 20 meters.
- Cause 3: The password of EX pos base is changed .
- Solution: Input the correct password , or restore factory setting to get the default password.

Q2: Why mobile phone can not search the 5G WiFi?

- Solution: Check whether mobile phone can support 5G WiFi.

6. Notes

Prevent the terminal from sun exposure, high temperature, moisture and other mean conditions.

Cut off the power before cleaning the device and wipe the main body with dry cloth. When the following abnormal phenomena occur, stop running the device immediately, cut off the power supply, and report to the service provider as soon as possible:

- Harsh noise heard during operation.
- Impurities or water found in the machine.
- Unpleasant smell found during operation.

7. Delivery and Storage

Deliver the device in normal way, avoiding rain and snow, sun exposure and mechanical impact.

The product should be stored in the original box. The box should be at least 15cm away from the floor, at least 50cm from the wall, heat source, cold source, window or air inlet.

8. Power Adapter

The base can only be connected to the adapter which is provided with AXIUM EX-MBASE-W1.

WARNING

The power adapter provided is specially designed for ingenico AXIUM EX-MBASE-W1. Do not use any other power supply. The use of a power supply with apparently similar voltage/current characteristics may damage your terminal.

ATTENTION

L'adaptateur secteur fourni est spécialement conçu pour l'ingenico AXIUM EX-MBASE-W1. N'utilisez aucun autre bloc d'alimentation. L'utilisation d'une alimentation avec des caractéristiques de tension / courant apparemment similaires peut endommager votre terminal.

9. Standards

FCC WARNING

This device complies with part 15 of the FCC Rules. Operation is subject to the following two conditions:

- This device may not cause harmful interference, and
- This device must accept any interference received, including interference that may cause undesired operation.

Any Changes or modifications not expressly approved by the party responsible for compliance could void the user's authority to operate the equipment

The antennas used for this transmitter must be co-located or operating in conjunction with any other antenna or transmitter.

RF exposure

The antenna of the product, under normal use condition is at least 20cm away from the body of the user. Warning statement to the user for keeping 20cm separation distance and the prohibition of operating to a person has been printed on the user manual. So, this product under normal use is located on electromagnetic far field between the human body.

Note: This equipment has been tested and found to comply with the limits for a Class B digital device, pursuant to part 15 of the FCC Rules. These limits are designed to provide reasonable protection against harmful interference in a residential installation. This equipment generates, uses and can radiate radio frequency energy and, if not installed and used in accordance with the instructions, may cause harmful interference to radio communications. However, there is no guarantee that interference will not occur in a particular installation. If this equipment does cause harmful interference to radio or television reception, which can be determined by turning the equipment off and on, the user is encouraged to try to correct the interference

by one or more of the following measures:

- Reorient or relocate the receiving antenna.
- Increase the separation between the equipment and receiver.
- Connect the equipment into an outlet on a circuit different from that to which the receiver is connected.
- Consult the dealer or an experienced radio/TV technician for help.

ISED WARNING

This device complies with Innovation, Science and Economic Development Canada license-exempt RSS standard (s). Operation is subject to the following two conditions:

- This device may not cause interference, and
- This device must accept any interference, including interference that may cause undesired operation of the device.

Le présent appareil est conforme aux CNR d'ISED applicables aux appareils radio exempts de licence.

L'exploitation est autorisée aux deux conditions suivantes:

- l'appareil ne doit pas produire de brouillage, et
- l'utilisateur de l'appareil doit accepter tout brouillage radioélectrique subi, même si le brouillage est susceptible d'en compromettre le fonctionnement.

RF exposure

The antenna of the product, under normal use condition is at least 20cm away from the body of the user. Warning statement to the user for keeping 20cm separation distance and the prohibition of operating to a person has been printed on the user manual. So, this product under normal use is located on electromagnetic far field between the human body.

Exposition aux RF

L'antenne du produit, dans des conditions normales d'utilisation, est à au moins 20 cm du corps de l'utilisateur. Une déclaration d'avertissement à l'utilisateur pour maintenir une distance de séparation de 20 cm et l'interdiction d'opérer à une personne a été imprimée sur le manuel de l'utilisateur. Ainsi, ce produit en utilisation normale est localisé sur un champ électromagnétique éloigné entre le corps humain.

In accordance with the Innovation Regulations, Science and Canada Economic Development, this radio transmitter may operate with an antenna of a type and maximum (or lower) gain approved for the transmitter by Industry Canada. In order to reduce the risk of radio interference to other users, the antenna type and its gain must be chosen so that the equivalent isotropically radiated power (e.i.r.p) does not exceed the intensity required by the antenna establishing a satisfactory communication.

5GHz Wifi should be used indoor only.

Le Wifi 5 GHz doit être utilisé à l'intérieur uniquement

Environment (WEEE, Batteries and packaging)

This product is labeled in accordance with European Directives 2012/19/EU concerning Waste Electrical and Electronic Equipment (WEEE) and 2013/56/EU concerning Batteries and Accumulators. Those provisions are requiring producers and manufacturers to become liable for take-back, treatment and recycling upon end of life of equipment and batteries.

THE PRODUCT



The crossed-out waste bin stuck on the product, or its accessories means that the product belongs to the family of electrical and electronic equipment, and waste batteries must not be thrown away but collected separately and recycled. Please contact your retailers for more detailed information about the compliance solution in place for disposing of your

old product and used batteries. Packaging waste must also be collected separately to assure a proper disposal and recycling. In this way you can participate in the re-use and upgrading of Electrical and Electronic Equipment Waste, which can have an effect on the environment and human health.

"INGENICO is a trademark of BANKS AND ACQUIRERS INTERNATIONAL HOLDING . This Document is Copyright © 2023 BANKS AND ACQUIRERS INTERNATIONAL HOLDING . BANKS AND ACQUIRERS INTERNATIONAL HOLDING retains full copyright ownership, rights and protection in all material contained in this document. The recipient can receive this document on the condition that he will keep the document confidential and will not use its contents in any form or by any means, except as agreed beforehand, without the prior written permission of BANKS AND ACQUIRERS INTERNATIONAL HOLDING. Moreover, nobody is authorized to place this document at the disposal of any third party without the prior written permission of BANKS AND ACQUIRERS INTERNATIONAL HOLDING. If such permission is granted, it will be subject to the condition that the recipient ensures that any other recipient of this document, or information contained therein, is held responsible to BANKS AND ACQUIRERS INTERNATIONAL HOLDING for the confidentiality of that information. Care has been taken to ensure that the content of this document is as accurate as possible. BANKS AND ACQUIRERS INTERNATIONAL HOLDING however declines any responsibility for inaccurate, incomplete or outdated information. The contents of this document may change from time to time without prior notice, and do not create, specify, modify or replace any new or prior contractual obligations agreed upon in writing between BANKS AND ACQUIRERS INTERNATIONAL HOLDING and the user. BANKS AND ACQUIRERS INTERNATIONAL HOLDING is not responsible for any use of this device, which would be non-consistent with the present document. All trademarks used in this document remain the property of their rightful owners"